

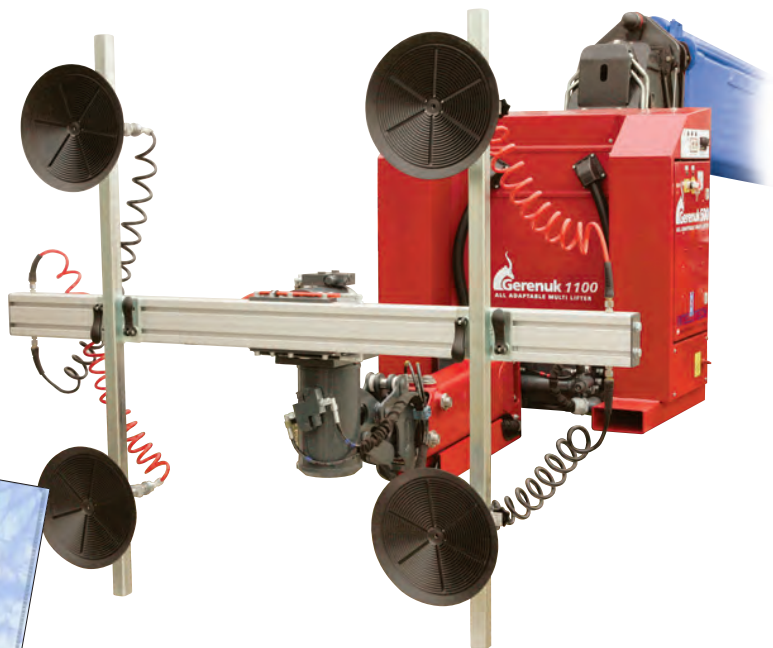

**Gerenuk® 1100 is a hydraulic, remote-controlled multi-purpose lifter which can be adapted to all telescopic loaders, cranes and other lifting gear to lift all types of building materials.**

We were proud to be second runner-up out of more than 80 rental products competing for **RENTAL PRODUCT OF THE YEAR 2010** by the ERA and World Rental News.



- Gerenuk® 1100 is a unit with integrated electrical and hydraulic systems and is thus independent of supply from the host machine.
- The unique head rotates and manipulates all items up to 1,100 lbs in every direction with very high precision.
- Very high level of safety with a 2-circuit vacuum system providing 400% overcapacity.
- Telescopic arm with 59" mounting depth and 16.5" projection enables manipulation and mounting over balconies or through scaffolding.
- Lifts and handles all known building materials, such as facade elements, glass, concrete, granite, wood, steel etc.



### Mounting of building materials from 0 to 120 yards



Glass



Facade elements



Concrete



Granite

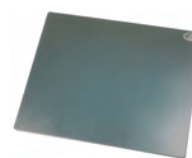

Steel



Wood

### Lifts and handles all known building materials

Production:



Made in Denmark  
Pat. pend.

Gerenuk® 1100

# Dimensions

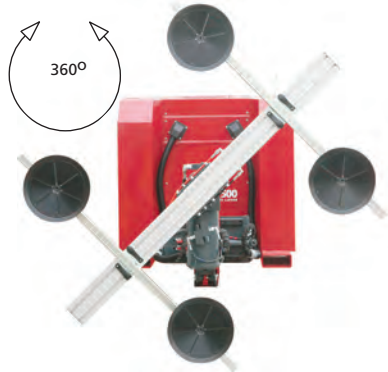
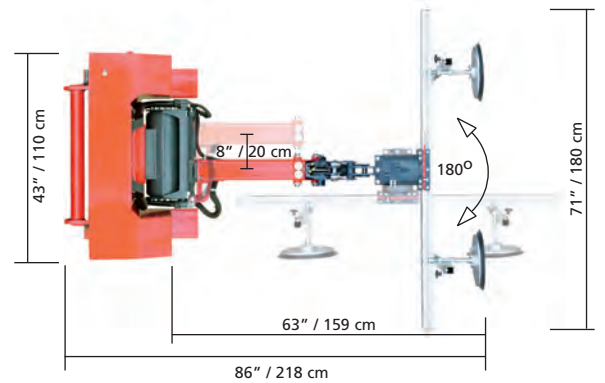
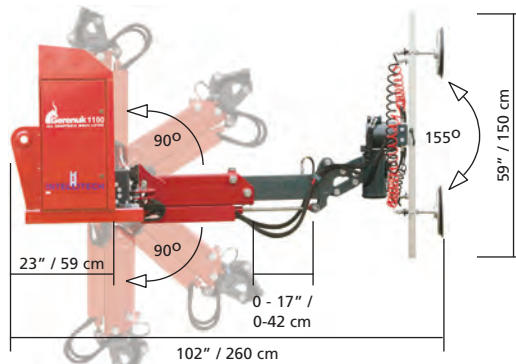

Description	Value	Description	Value
Loading capacity	1100 lbs / 500 kg	Sideshift	8" / 200 mm
Own weight	1590 lbs / 720 kg	Telescopic arm	17" / 420 mm
Machine min. width	43" / 1100 mm	Working arc	180 degrees +
Machine length	36" / 900 mm	Battery	24 V (2x12 V)
Machine height	69" / 1750 mm	Charging time	Approx. 12 hours
Battery life	Approx. 12 hours	Charging current	230 or 115 V

# Operations



The operator stands on scaffolding or other areas close to the mounting and uses the remote control to precisely adjust the load to the millimeter.



Gerenuk® 1100 is powered by its own, integrated battery, has a closed hydraulic system and is maneuvered using a remote control.



The special design of the Gerenuk® 1100 enables mounting of e.g. window sections on balconies from the outside.



It is thus a unique unit which is independent of the host machine and can therefore be used on any machine on which it is mounted.

Dealer stamp

**GLG Canada Limited**  
 London, ON  
 Email: info@glgcan.com  
 Call Toll Free: 1-855-779-3371

Gerenuk® 1100