

GLASLIFT[®] 500/1100 Multilifter

 Made in Denmark
Pat. pend.

The most intelligent remote controlled robotic multilifter with 3D manipulation, sensor surveillance and remote repair utilities.



Unique

manipulation

Up to 5 meters
in all angles.

Inside out fitting.

Unique handling

3D manipulation



Unique

manipulation

The strong, and extremely precise head, on which the front system is mounted, has a sturdy design which means, that the front system can rotate and tilt the elements in all directions. Consequently, the mounting options are almost unlimited.

Millimeter precise



Power is a factor, if you can control it. With the Glaslift[®] 500/1100 you can fit elements millimeter precise with the sensitive remote control. The whole HHI concept of Power & Precision applies to its full extend in the Glaslift[®] 500/1100 handling abilities.

Unique safety

Sensor surveillance



The position of the machine and the load is constantly monitored by the on-board Sensor Surveillance System, to ensure full use of the load envelope and maximum safety.

400% overcapacity



A two-circuit vacuum system ensures that the suction discs always have 400% overcapacity. A visual - and an acoustic alarm ensure that the machine is not operated until the system has reached optimum suction power. This makes the vacuum system one of the safest systems in the world.

Unique service

Remote service



The Glaslift[®] 500/1100 can go online and be remotely serviced. This enables speedy diagnostics, remote programming and tailored repairs. The onboard computer supervises all systems and reports any damage.

All round adaptability



You can adapt the Glaslift[®] 500/1100 to lifting any kind of building material. Suction discs specially adapted to lifting porous materials like wood or plasterboard are available as optional extras. They also handle materials with rough surfaces like e.g. granite.

GLASLIFT[®] 500/1100 Multilifter

 Made in Denmark
Pat. pend.

Technical data

Description	Value
Loading capacity	500 kg
Own weight	1410 kg
Machine min. width	890 mm
Machine max. width	1750 mm
Machine min. length	3500 mm
Machine min. height	1900 mm
Autonomy	8 hours
Front wheels	Solid rubber
Rear wheels	Hard composite
Charging current	220 or 110 V
Battery specs.	12 x 2 V (24 v)
Charging time	10-100% 8 hours
Charging time	25-70% 1 hour

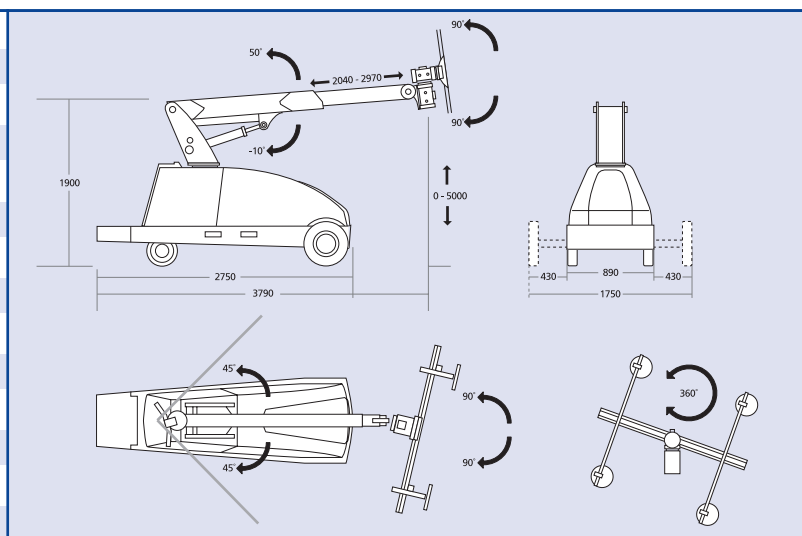

Range

The GlasLift[®] 500/1100 can lift objects from floor level up 5 meters in all directions.
That enables fitting on 1.st floor level from the ground.

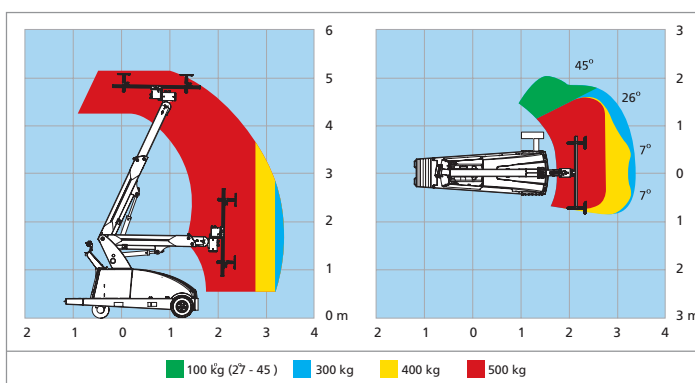

Stability



The front wheels are mounted on sturdy, stable, square axles that can slide to the sides. This gives the GlasLift[®] 500/1100 unique stability.

Unique adaptability

Materials

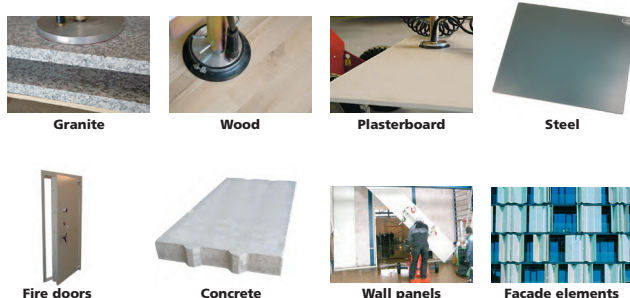

Narrow passages

With both front wheels at the inmost position, the machine is able to drive through a passage of merely 89 cm.



GlasLift[®] 500/1100 complies with the requirements of Machinery Directive 2006/42/EC.

Please contact HH-Intellitech to book a demonstration.

meszoforte.uk

Sales:



Phone: 1.855.779.3371 | E-mail: sales@glgcan.com | www.glgcan.com