

**MRT49DC
MRT411LDC
MRT4HV11DC**

With three frame configurations, 90° tilt and continuous 360° rotation, these Powr-Grip® vacuum lifters deliver maximum versatility and range of motion in the shop or at the construction site.

Standard Pad Spread: MRT49DC

- 25-1/4" x 30" [642 x 760 mm] (basic configuration)
- 45-1/4" x 64-3/4" [1152 x 1643 mm] (extended configuration)
- 75-1/4" x 12-3/4" [1914 x 323 mm] (linear configuration)

Standard Pad Spread: MRT411LDC

add 2-3/4" [73 mm] to each dimension listed above

Standard Pad Spread: MRT4HV11DC

add 1-3/4" [48 mm] to each dimension listed above

Number / Size of Pads:

- MRT49DC - 4 / 9" [229 mm] diameter
- MRT411LDC - 4 / 11" [280 mm] dia. lipped
- MRT4HV11DC - 4 / 10" [254 mm] dia. lipped

Load Capacity:

- MRT49DC - 500 lbs. [225 kg]
- MRT411LDC - 700 lbs. [320 kg]
- MRT4HV11DC - 600 lbs. [270 kg]

(On smooth, nonporous surfaces.)

Please contact us for recommendations on other surfaces.)

Average Unit Weight: 122 lbs. [56 kg]

Standard Operating Power: 12 volts DC, 10 amps

Load Movement: Manual rotation, 360° edgewise, with locking at each quarter point.
Manual tilt, 90° between upright and flat, with automatic latching in upright position.

- Low vacuum warning light
- On-board battery and charger
- Battery energy gauge
- Vacuum gauge
- Vacuum line filter
- Vacuum reserve tank
- Spring-mounted pads
- Movable pad mounts
- Extension arms

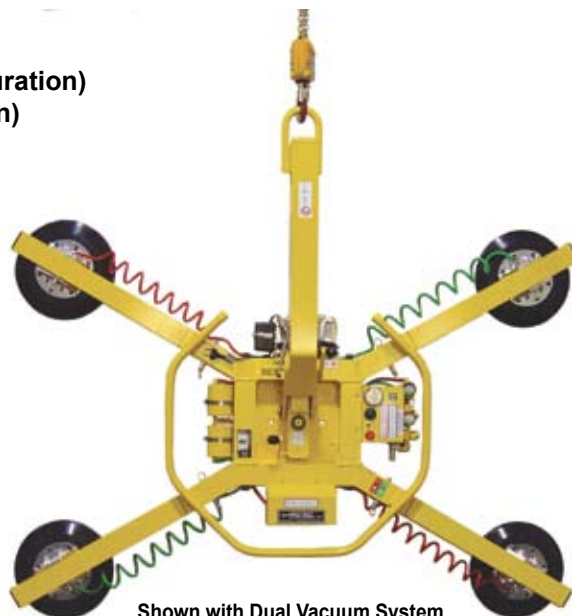

Shown with Dual Vacuum System

AVAILABLE OPTIONS:

- Long extension arms (CF5LEAO)
- Individual pad shutoffs (CM1COWB)
- Closed cell foam pad rings (FRHV11)
(Available on MRT4HV11 units only)
- Dual vacuum system (EO10DVS)
- Adaptable length lift bar (LB6ALO)
- Forklift adapter (LB7FAO)

Linear Configuration

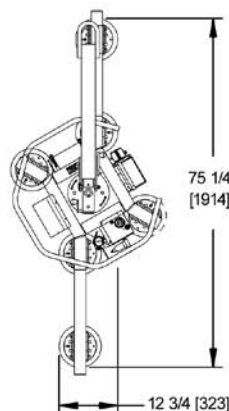

Basic Configuration

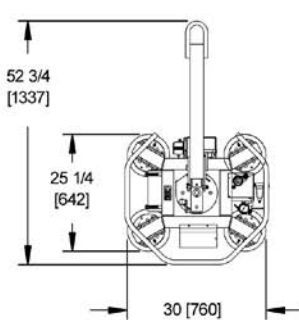

Extended Configuration

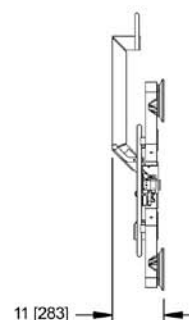
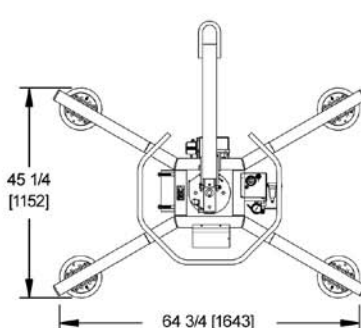

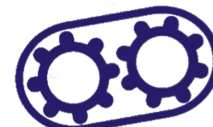

trackedaccess

MRT OPTIONS

Adaptable Length Lift Bar (LB6ALO)

Designed for applications requiring increased horizontal reach at the hook point or applications involving minimal clearance between the lifter and the hoisting equipment, such as installations under eaves or similar handling situations.

Overhead Clearance Reduction: 11-3/4" [298 mm] with Shortened Configurations (C or D)

Horizontal Reach Increase: 7-5/8" [193 mm] with Reversed Bail Configurations (B or D)

Maximum Load Capacity*:

- A) Standard Configuration: 700 lbs. [320 kg]
- B) Reversed Bail Configuration: 600 lbs. [270 kg]
- C) Shortened Configuration: 650 lbs. [295 kg]
- D) Shortened, Reversed Bail Configuration: 500 lbs. [225 kg]

*Net capacity cannot exceed standard lifter capacity.

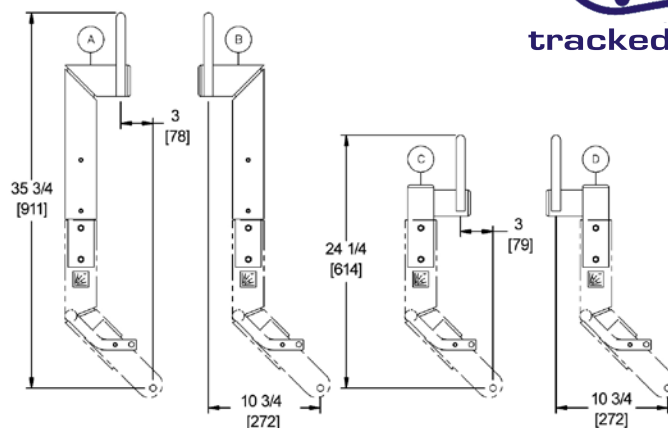

Forklift Adapter (LB7FAO)

Designed for applications where a forklift is desired, such as installations under eaves and commercial, indoor applications, where using a crane is not possible.

Compatible Fork Dimensions: 1-1/2" to 2-1/4" [38-57 mm] thick and 4" to 6" [102-152 mm] wide
Inside Fork Spread: 4" [102 mm]

Maximum Load Capacity: 700 lbs [320 kg] when used on MRT411LDC*

Maximum Load Thickness: 1" [25 mm] at full capacity

*The forklift must have sufficient capacity for the combined weight of the lifter and its maximum load when the load is located 8-3/4" [222 mm] outward from the fork tips or 50-3/4" [1289 mm] outward from the fork stops, whichever places the load at a greater distance from the forklift's front wheels.

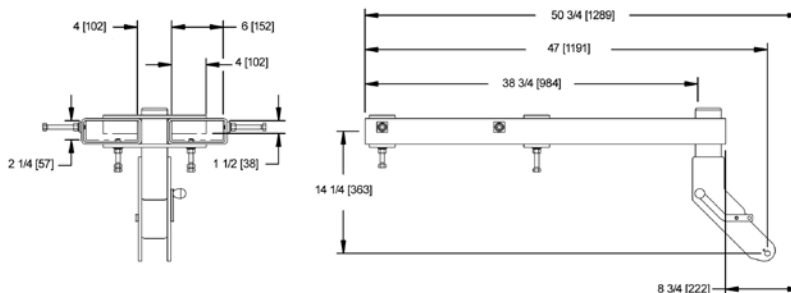

Long Extension Arms (CF5LEAO)

Designed for applications requiring a larger pad spread to reduce overhang on large loads.

Maximum Load Capacity: 500 lbs. [225 kg] (with long arms installed)

Pad Spread Dimensions provided are for MRT49DC.

For MRT411LDC, add 2-3/4" [73 mm]

For MRT4HV11DC, add 1-3/4" [48 mm]

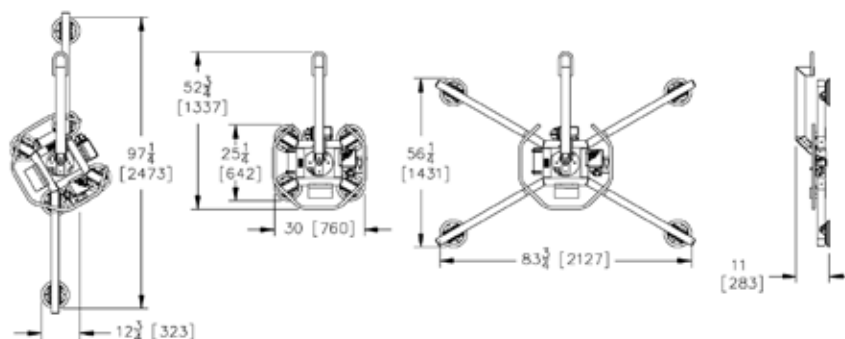

Tracked Access Ltd

Access & Lifting Specialists

t: 0845 603 5360 / f: 0845 603 5361

info@trackedaccess.com

www.trackedaccess.com