

VACUUM LIFTER (GVI)



The GVI line is a separate product range. Suction cups are in fact equipped with independent controls, built-in battery and safety devices. They are used for fast and safe handling of glass panes and flat panels. Several models are available with varying lifting capacity. They are used in combination with any machine fitted with a hook lifting system.

The models available are:

- ✓ GVI4L (4 suction cups in line)
- ✓ GVI4+2LX (4 in-line + 2 extra suction cups)
- ✓ GVI6+6 (12 suction cups)

GVI 4L / GVI 4+2 LX



Technical Information



Dimension L x W x H	1165 x 620 x 822 mm
N. of Pads	4 + 2

Weight	50 kg
Elect. System	12V
Pad Diameter	300 mm
Max SWL	540 kg
Tilting Angle	0°/90°
Swiveling Angle	± 90°

	4 L	4+2LX
N. of Pads	4	6
Factory Use	360 kg	540 kg
Building Site Use	180 kg	270 kg

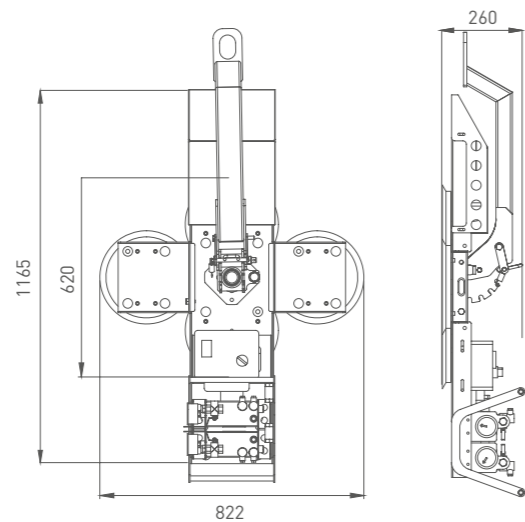

GVI 6+6

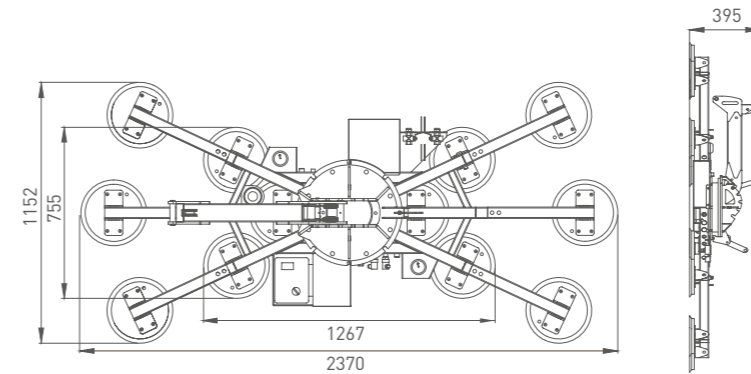

Technical Information

Dimension L x W x H	2730 x 395 x 1152 mm
N. of Pads	6 + 6

Weight	140 kg
Elect. System	12V
Pad Diameter	300 mm
Max SWL	1000 kg
Tilting Angle	0°/90°
Swiveling Angle	360°



N. of Pads	2	4	6	8	10	12
Factory Use	180 kg	360 kg	540 kg	720 kg	900 kg	1000 kg
Building Site Use	90 kg	180 kg	270 kg	360 kg	450 kg	540 kg